

Delta SubSea

3 Inch Hard Line Cutter

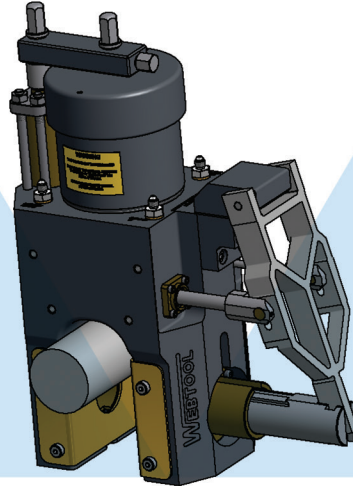

The RCV75HD is a double acting tool primarily intended for use on steel wire rope, having a maximum tensile strength of 1770N/mm and will cut ropes up to 75mm diameter. It may be used on alternative materials, such as electrical power or communication cables, again up to a maximum of 75mm diameter.

Four tapped Holes, M10 x20mm deep, are provided in the tool body on each face which can be used for any attachment necessary to mount the cutter. The cylinder is a pressure vessel and is not recommended as a mounting point, the cylinder should not be drilled, machined, mutilated or damaged in any way, any warranty could be invalidated by such actions.

A relief valve should also be incorporated in the return line. This is to prevent excessively high pressures in the annular side of the hydraulic cylinders should the return to tank become blocked for any reason.

The oil supply must be clear and free from contamination. A good quality ISO32 grade hydraulic oil, e.g. Shell Tellus 32 or equivalent, is suitable.

Features

Function

Max Working Pressure

Swept Volume

	<i>psi</i>	<i>bar</i>	<i>ml.</i>	<i>U.S. Gallon</i>
Working Stroke	3,190	220	500	(0.13)
Return Stroke	3,190	220	420	(0.11)
Auxiliary Cylinders	3,040	210		

Specifications

Weight:

▲ 43kg

Water Depth:

▲ 3,000m

Delta SubSea

DeltaSubSea-ROV.com

1.936.582.7237