

Delta SubSea

Flex Joint Cleaning Tool

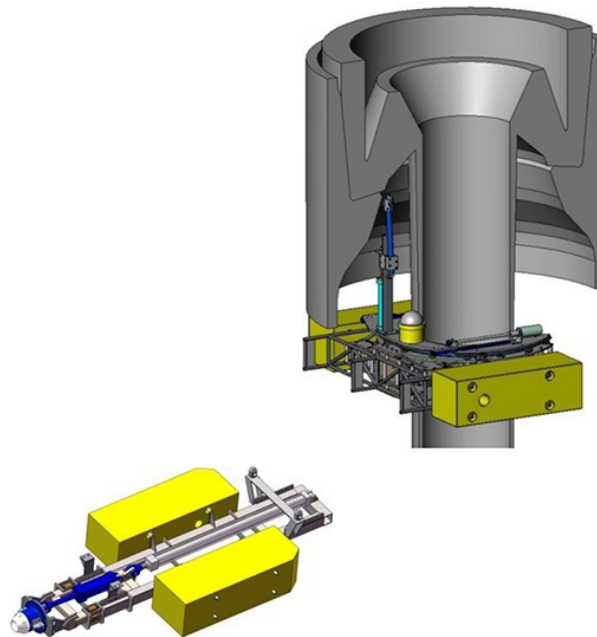

The Flex Joint cleaning tool was designed to clamp around Subsea Flex Joints with pipeline diameters ranging from 8" to 24". The purpose of the tool is to thoroughly clean the underside of the Flex Joint by removing excessive marine growth from the elastomer allowing for optimal inspection. The tool is operated by a Delta SubSea Technician through the use of a joystick, tooling computer with GUI interface inside the ROV control van. The unique deployment system of the tool allows it to be used on many of the industry recognized work-class ROV's. The tool is designed with interchangeable tool trays which provides the option to work with various inspection cameras, lasers, temperature probes, cleaning tools, etc...



Delta SubSea
DeltaSubSea-ROV.com
1.936.582.7237

*Delta SubSea is not the manufacturer of this product.